

# DRUM ROLLING MIXERS

## DRUM ROLLING MIXERS

	Page No.
General Information	F1
Technical Data	F2
.....	
.....	
.....	
.....	

- \* Dimensions in mm unless otherwise specified
- \* Specifications may change without notification

# RRM

## DRUM ROLLING MIXERS

### Drum Rolling Mixer FRM 50/200



Drum Rolling Mixer

FRM 50/200

#### Range of Application

For mixing, rearrangement, burr removing, dissolving, emulsifying, grinding etc. of powders, granules, liquids and solid liquid mixtures.

#### Operation

The drum is put onto the roller track and is centred by means of the adjustable fixing device with ball rollers. As soon as the machine is switched on, the horizontal mixing movement starts. According to the EC directives, a protective device has to be provided for the area of rotation.

#### Advantages

- mixing, rearrangement, burr removing, dissolving, emulsifying, grinding etc.
- construction sizes for 50 to 200 l
- variable speed
- as an option conformity to ATEX acc. to regulation 94/9 EC



# RRM

## DRUM ROLLING MIXERS

### Drum Rolling Mixer FRM 50/200

#### Technical Data

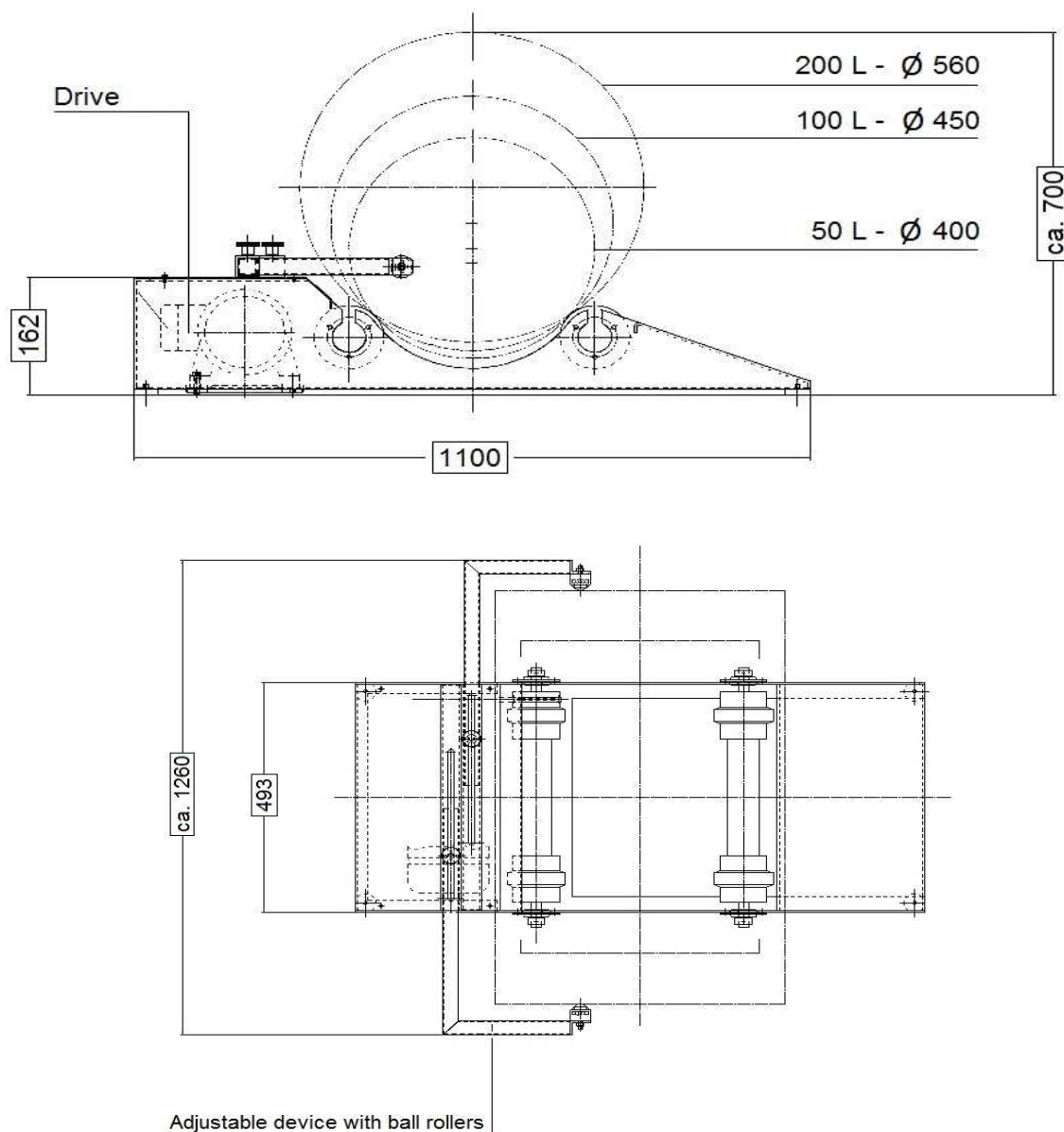

Further free-fall mixers included in our manufacturing programme:

- container mixers
- double cone mixers
- drum hoop mixers
- tumbling mixers

#### CALMORE MACHINERY CO LTD

UNIT 4, 28 BLACK MOOR ROAD, EBBLAKE INDUSTRIAL ESTATE,  
VERWOOD, BH31 6BB, UK

TEL: +44 (0)1202 827701 FAX: +44 (0)1202 813053

Email: [info@calmorehinges.co.uk](mailto:info@calmorehinges.co.uk)

[www.calmorehinges.co.uk](http://www.calmorehinges.co.uk)